

# Wi-Safe Remote Warning Sounder

A.K.A. Wi-Safe Remote Warning Handset

## Product Image



## Product Dimensions (mm)

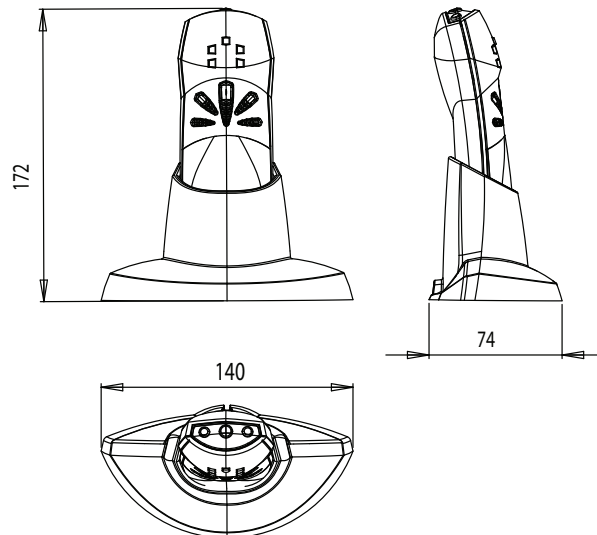

<b>Model Number</b>	WBS-616
<b>Retail Description</b>	Wi-Safe Remote Warning Handset
<b>Retail EAN Number</b>	0816317000615
<b>Retail Packaging Format</b>	Cardboard Box with PET Tray and Window
<b>Retail Packaging Dimensions WxHxD</b>	183mm x 266mm x 78mm
<b>Retail Packaging Weight</b>	662g (including Remote Sounder, AC/DC mains adaptor, manual and batteries)
<b>Retail Outer Box Quantity</b>	3
<b>Trade Description</b>	Wi-Safe Remote Warning Sounder
<b>Trade EAN Number</b>	0816317000615
<b>Trade Packaging Format</b>	Cardboard Box with PET Tray and Window
<b>Trade Packaging Dimensions WxHxD</b>	183mm x 266mm x 78mm
<b>Trade Packaging Weight</b>	662g (including Remote Sounder, AC/DC mains adaptor, manual and batteries)
<b>Trade Outer Box Quantity</b>	3
<b>Warranty</b>	5 Years
<b>Technology</b>	Light: Bright Escape Torch Communication: Wi-Safe Wireless
<b>Operation AC/DC</b>	AC mains with DC battery backup
<b>Battery Type</b>	9 volt Alkaline
<b>Product Weight</b>	520g (Including battery)
<b>Alert Type</b>	Loud 85dB alarm at 3 metres Bright flashing light Alarm type LED indicators

<b>Operating Temperature</b>	-5°C to 40°C
<b>Operating Humidity</b>	Up to 90% RH non-condensing
<b>Installation Positions</b>	Next to sleeping or sitting position
<b>Approvals</b>	Independently tested to conform to the following european standards: Clauses of BS EN 14604: 2005 EN 60065 (2002) EN 50130-4 (1995) ETSI EN 301 489-3 v1.4.1 (2002-08) ETSI EN 301 489-1 v1.6.1 (2005-09) EN 300 220 -1 v1.3.1 (2000) EN 300 220-3 v1.1.1 (2000) BS EN 61000-6-3 (2001) BS EN 60950 (2001)
<b>Wi-Safe RF</b>	433.920 MHz 24-bit encryption
<b>WBS-616 receives signals from</b>	WSI-601, WSO-601, WSO-610, WLSO-610, WCO-628
<b>Wi-Safe Product Memory</b>	20 alarms

## Health & Safety Information

<b>Storage Temperature</b>	-20°C to +60°C
<b>Storage Humidity</b>	Up to 93% RH non-condensing

