

WSO-601 Datasheet Alkaline Wi-Safe Optical Smoke Alarm

GN0241/RI

Product Image



Product Dimensions (mm)

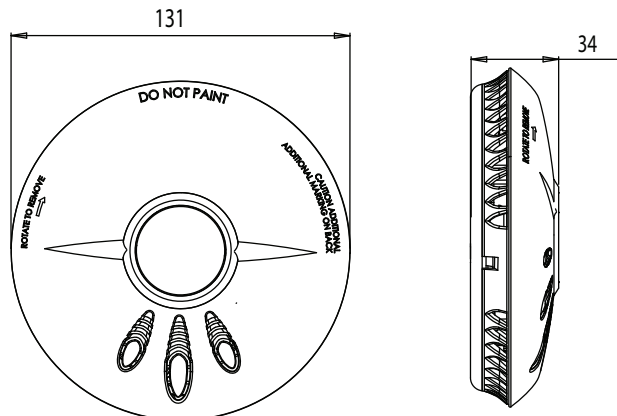

Model Number	WSO-601
Retail Description	N/A
Retail EAN Number	N/A
Retail Packaging Format	N/A
Retail Packaging Dimensions WxHxD	N/A
Retail Packaging Weight	N/A
Retail SRP Quantity	N/A
Trade Description	Wi-Safe Optical Smoke Alarm
Trade EAN Number	0816317000660
Trade Packaging Format	Recycled Cardboard Box
Trade Packaging Dimensions WxHxD	134mm x 134mm x 40mm
Trade Packaging Weight	226g (including alarm, manual and fixings)
Trade Outer Box Quantity	20
Warranty	10 years
Technology	Sensor: Optical (Photoelectric) Communication: Wi-Safe Advanced Wirefree Technology
Operation AC/DC	DC
Battery Type	9 volt PP3 - Alkaline
Product Weight	175g (Including battery)

Alert Type	Loud 85dB alarm at 3 metres + red flashing LED
Operating Temperature	+4°C to +38°C
Operating Humidity	Up to 90% RH non-condensing
Installation Positions	Ceiling / Wall
Approvals	Certified to BS EN 14604:2005 ETSI EN 301 489-1 v1.6.1 (2005-09) ETSI EN 301 489-3 v1.4.1 (2002-08) EN 300 220-3 v1.1.1 (2000) BS EN 60065 (2002) BS EN 60950 (2001) EN 50130-4 (1995) BS EN 61000-6-3 (2001)
Wi-Safe RF	433.920 MHz 24-bit encryption
WSO-601 connects to	WBS-616, WWP-626, WFS-627, WFSVP-629

Health & Safety Information

Storage Temperature	-20°C to +60°C
Storage Humidity	Up to 93% RH non-condensing
Storage Licensing Requirement	N/A
Isotope Activity	N/A



Certificate No. 651d/06
to BS EN 14604:2005

FireAngel®

FireAngel Ltd.
The Technocentre, Puma Way
Coventry CV1 2TT UK

Tel +44 (0)24 7623 6600
Fax +44 (0)24 7623 6603
Web www.fireangel.co.uk