

WVP-626 Datasheet Trade

Wi-Safe Vibrating Alert System

A.K.A. Wi-Safe Vibrating Alarm

GN0235/RI

Product Image



Product Dimensions (mm)

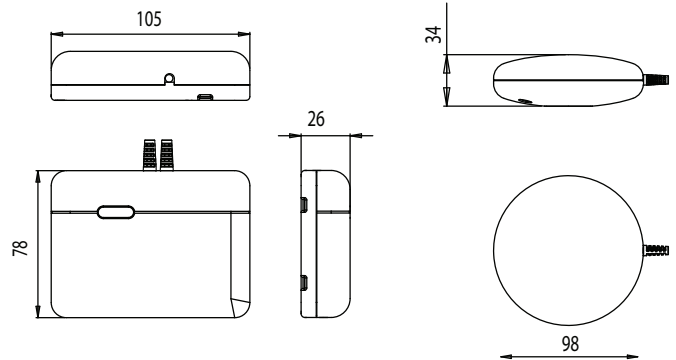

Model Number	WVP-626
Retail Description	N/A
Retail EAN Number	N/A
Retail Packaging Format	N/A
Retail Packaging Dimensions WxHxD	N/A
Retail Packaging Weight	N/A
Retail Outer Box Quantity	N/A
Trade Description	Wi-Safe Vibrating Alert System
Trade EAN Number	0816317000820
Trade Packaging Format	Recycled Cardboard Box
Trade Packaging Dimensions WxHxD	155mm x 70mm x 112mm
Trade Packaging Weight	431g (Including Wi-Safe Vibrating Alert System, AC/DC mains adaptor, manual, batteries and fixings)
Trade Outer Box Quantity	24
Warranty	10 Years
Technology	Communication: Wi-Safe Wireless
Operation AC/DC	AC mains with DC rechargeable battery
Battery Type	Rechargeable Ni-Mh battery only
Product Weight	350g (including battery)
Alert Type	Individual vibration and LED patterns for smoke and carbon monoxide alert

Operating Temperature	-5°C to +40°C
Operating Humidity	Up to 90% RH non-condensing
Installation Positions	Vibrating Pad: Under pillow, mattress or seating cushion Receiver Box: On wall or surface
Approvals	Independently tested to conform to the following european standards: EN 301 489-1 v1.6.1 (2005-09) EN 301 489-3 v1.4.1 (2002-08) EN 300 220-3 v1.1.1 (2000) BS EN 60065 (2002) BS EN 60950 (2001) BS EN 50130-4 (1995) BS EN 55022 (2006)
Wi-Safe RF	433.920 MHz 24-bit encryption
WVP-626 receives signals from	WSI-601, WSO-601, WSO-610, WLSO-610, WCO-628
Wi-Safe Product Memory	20 alarms

Health & Safety Information

Storage Temperature	-20°C to +60°C
Storage Humidity	Up to 93% RH non-condensing



FireAngel®

FireAngel Ltd.
The Technocentre, Puma Way
Coventry CV1 2TT UK

Tel +44 (0)24 7623 6600
Fax +44 (0)24 7623 6603
Web www.fireangel.co.uk